

Rosemount 5900S Radar Level Gauge

High performance level measurement
for tank gauging systems



- Get highest certified custody transfer accuracy for precise monitoring of bulk liquid assets
- Achieve higher safety with third party certified IEC 61508 SIL 2 or SIL 3 capability
- Enable redundant level measurement with innovative 2-in-1 functionality
- Benefit from convenient and safe installation with 2-wire IS bus power supply
- Include wired and/or wireless data transmission
- Measure in all bulk storage tank types and products, ranging from liquefied gases, light products, crude oil and bitumen

Improve measurement accuracy, plant efficiency and safety

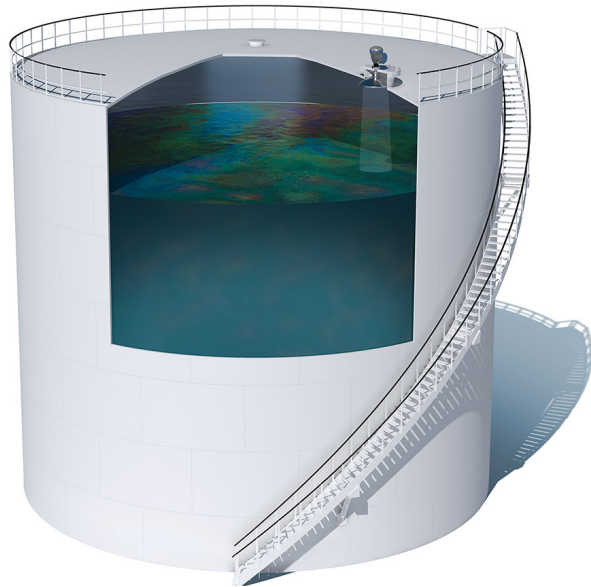

Highest level precision for your bulk liquid storage tanks

The 5900S gauge with its 0.5 mm instrument accuracy reduces level measurement uncertainty to a minimum. It enhances your storage operation by providing:

- Certified custody transfer accuracy according to OIML and other legal metrological authorities
- Better inventory management
- Reliable loss control data

The 5900S is normally combined with high precision multi-spot temperature sensors for highest accuracy API standard net volume calculations.

Make operations more efficient

- No moving parts gives increased reliability and fewer interruptions
- Most 5900S antenna types are installed with the tanks in operation
- Emerson Smart Wireless can drastically reduce installation cost and give you access to remote tanks
- The 5900S is an integrated part of complete tank gauging solutions from Emerson who has supplied tank gauging for more than 100 000 bulk liquid storage tanks



Taking overfill safety to a higher level

- Innovative 2-in-1 feature with two radar gauges in one housing for independent level and overfill measurement
- SIL 2 and SIL 3 certified safety according to IEC 61508
- Enables API 2350 compliant solutions

Contents

Ordering information	4	Product Certifications	23
Specifications	18	Dimensional Drawings	26

Get complete level and inventory information

The Rosemount 5900S is a premium non-contact radar level gauge with custody transfer accuracy, suitable for tank terminals and refineries. It is normally integrated into a high performance tank gauging system including average temperature measurement for accurate net volume calculation. Data is transmitted to the control room and displayed on a host computer or the TankMaster inventory software package.

Using an Emerson Smart Wireless solution is an alternative that saves installation cost for remotely located tanks and where long distance field wiring is obsolete.

The 5900S gauge is available with antenna options to suit all bulk liquid storage applications and tank types.

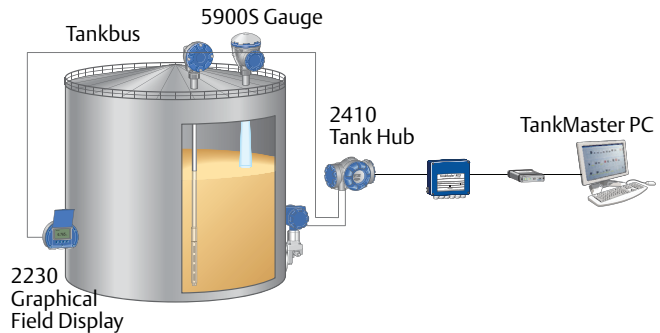

Drip-off means no condensation

Since the antenna has an inclined polished PTFE surface where microwaves are emitted, it will be less susceptible to condensed water or product. Condensation drops will not coat the active antenna part, so the radar signal remains strong, resulting in higher accuracy and better reliability.

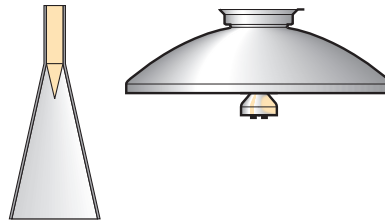

SIL safety functions

Rosemount 5900S is certified SIL 2 and SIL 3 capable for use in overfill prevention systems.

5900S with SIL option activates a separate alarm loop at a preset liquid level and triggers the safety relay output on the Rosemount 2410 Tank Hub. The alarm signal can be connected to an Emergency Shut-down System (ESD) / Automatic Overfill Prevention System (AOPS).

SIL 2 requires one 5900S. SIL 3 is achieved with a 2-in-1 5900S. A Rosemount 2410 Tank Hub equipped with a SIL relay output is also required for SIL safety.

2-in-1 gauge for cost-efficient level measurement redundancy

The 5900S gauge can be delivered with two electronic units integrated in the transmitter head.

The unique 2-in-1 solution gives you one primary and one backup unit in a single level gauge, or one level gauge plus an independent radar based High-High level alarm.

The 2-in-1 solution enables real-time delta verification by configuring the transmitter to compare signals on both units.

Compared to having two separate gauges, the 2-in-1 solution makes mechanical and electrical installation easier.



5900S with two galvanically separated gauges within the same housing (2-in-1 solution).

Ordering information

Rosemount 5900S Radar Level Gauge with parabolic antenna



Rosemount 5900S with parabolic antenna is a premium non-contact radar level gauge. It is the first choice for installation on tanks with fixed roofs without a still-pipe. The parabolic antenna can be installed on existing manhole covers and close to the tank wall due to the narrow radar beam and high signal to noise ratio. In certain cases, it can be used on tanks with floating roofs to measure the distance down to a target plate on the roof.

- Measures all products ranging from light products to heavy fuel oil, bitumen and asphalt
- Antenna design gives extreme tolerance to product build-up and condensation
- Custody transfer accuracy according to OIML R85:2008
- Certified SIL 2 and SIL 3 capable according to IEC 61508
- 2-in-1 functionality available for redundant level measurement
- Communicates via a 2-wire, low voltage Tankbus for easy and safe installation
- Installation normally with tank in service

Table 1. 5900S Radar Level Gauge with parabolic antenna ordering information

Model	Product Description
5900S	Radar Level Gauge
Performance Class	
P	Premium: ± 0.5 mm (0.020 in.) instrument accuracy
Safety Certification (SIS)	
3 ⁽¹⁾	Certified IEC 61508 SIL 3 capable
2 ⁽²⁾	Certified IEC 61508 SIL 2 capable
F	None. Ready for upgrade of safety certification (SIS)
0	None
Redundancy	
2	2-in-1; Independent radar level gauge electronics
F	None. Ready for upgrade to 2-in-1
1	None. Single radar level gauge electronics
Tankbus: Power and Communication	
F	Bus powered 2-wire FOUNDATION™ fieldbus (IEC 61158)

Table 1. 5900S Radar Level Gauge with parabolic antenna ordering information

Hazardous Location Certification	
I1	ATEX Intrinsic Safety
I2	Brazil Inmetro Intrinsic Safety
I5	FM-US Intrinsic Safety
I6	FM-Canada Intrinsic Safety
I7	IECEx Intrinsic Safety
KA	ATEX Intrinsic Safety+FM-US Intrinsic Safety
KC	ATEX Intrinsic Safety+IECEx Intrinsic Safety
KD	FM-US Intrinsic Safety+FM-Canada Intrinsic Safety
NA	None
Custody Transfer Type Approval	
R ⁽³⁾⁽⁴⁾	OIML R85 E performance certification
C ⁽³⁾⁽⁵⁾	PTB Eich (German W&M approval)
N ⁽⁵⁾⁽⁶⁾	NMi (Dutch W&M approval)
A ⁽³⁾⁽⁴⁾	CMI (Czech W&M approval)
E ⁽³⁾⁽⁴⁾	TJA (Estonian W&M approval)
Y ⁽³⁾⁽⁴⁾	Justervesenet (Norwegian W&M approval)
M ⁽⁴⁾⁽⁶⁾	BMS (Belgian W&M approval)
W ⁽³⁾⁽⁴⁾	METAS (Swiss W&M approval)
0	None
Radar Measurement Method	
1	10 GHz FMCW radar technology
2	10 GHz FMCW radar technology for the US market
Housing	
A	Standard enclosure, polyurethane-covered aluminum. IP 66/67
Cable / Conduit Connections	
1	½ - 14 NPT, female thread. 1 plug included
2	M20 x 1.5 adapters, female thread. 2 adapters and 1 plug included
G	Metal cable glands (½ - 14 NPT). Min. temperature -20 °C (-4 °F). ATEX / IECEx Exe approved. 2 glands and 1 plug included
E	Eurofast male connector, 1 plug included
M	Minifast male connector, 1 plug included
Antenna	
1P	Parabolic antenna
Antenna Size	
F	20 in. / DN 500, Ø=440 mm (17.3 in.)

Table 1. 5900S Radar Level Gauge with parabolic antenna ordering information

Antenna Material	
S	Stainless steel (material type corresponding to AISI 316L/EN 1.4436)
Tank Seal	
PF	PTFE with FEP fluoropolymer o-ring
Tank Connection	
WE ⁽⁷⁾	Welded installation
CL ⁽⁷⁾	Clamped/threaded installation
Special	
0	None
V ⁽⁸⁾	Proof test reflector kit (size equal to tank connection)
Options (Include with selected model number)	
WR3	Extended Product Warranty: 3-year limited warranty
WR5	Extended Product Warranty: 5-year limited warranty
QT ⁽⁹⁾	IEC 61508 certificate and FMEDA-data
Q4	Calibration certificate
S4	Calibration certificate, witnessed by factory selected accredited third party
Q8 ⁽¹⁰⁾	Antenna material traceability certification per EN 10204 3.1
ST	Engraved SST tag plate
U1 ⁽¹¹⁾	TÜV/DIBt WHG approval for overfill protection
Typical Model Number: 5900S P 2 F F I5 R 2 A 1 1P F S PF WE 0 Q4	

- (1) Requires Redundancy code 2 and Rosemount 2410 Tank Hub with Relay Output (SIS/SIL) code 3. Alarm if one of the two gauges is in alarm mode.
- (2) Requires Rosemount 2410 Tank Hub with Relay Output (SIS/SIL) code 2.
- (3) Requires Options code Q4.
- (4) Requires Rosemount 2410 Tank Hub with the corresponding Custody Transfer Type Approval. Integral 2410 display or Rosemount 2230 display or TankMaster required. Approval plate and sealing kit included.
- (5) Requires Rosemount 2410 Tank Hub with the corresponding Custody Transfer Type Approval. Integral 2410 display or Rosemount 2230 display (with corresponding type approval) or TankMaster required. Approval plate and sealing kit included.
- (6) Requires Options code S4
- (7) Flange not included.
- (8) Not available with Options code U1.
- (9) Requires Safety Certification (SIS) code 2 or 3.
- (10) Certificate includes all pressure retaining wetted parts.
- (11) Requires one or more relay outputs in the Rosemount 2410 Tank Hub.

Rosemount 5900S radar level gauge with horn antenna



Rosemount 5900S with horn antenna is a non-contact radar level gauge. It is designed for easy installation on fixed roofs tanks, with smaller nozzles, down to 200 mm (8 in.).

- Measures on a variety of products except asphalt or similar for which the parabolic antenna is recommended
- Custody transfer accuracy according to OIML R85:2008
- Certified SIL 2 and SIL 3 capable according to IEC 61508
- 2-in-1 functionality available for redundant level measurement
- Communicates via a 2-wire, low voltage Tankbus for easy and safe installation
- Installation normally with tank in service

Table 2. 5900S Radar Level Gauge with horn antenna ordering information

Model	Product Description
5900S	Radar Level Gauge
Performance Class	
P	Premium: ±0.5 mm (0.020 in.) instrument accuracy
Safety Certification (SIS)	
3 ⁽¹⁾	Certified IEC 61508 SIL 3 capable
2 ⁽²⁾	Certified IEC 61508 SIL 2 capable
F	None. Ready for upgrade of safety certification (SIS)
0	None
Redundancy	
2	2-in-1; Independent radar level gauge electronics
F	None. Ready for upgrade to 2-in-1
1	None. Single radar level gauge electronics
Tankbus: Power and Communication	
F	Bus powered 2-wire FOUNDATION™ fieldbus (IEC 61158)

Table 2. 5900S Radar Level Gauge with horn antenna ordering information

Hazardous Location Certification	
I1	ATEX Intrinsic Safety
I2	Brazil Inmetro Intrinsic Safety
I5	FM-US Intrinsic Safety
I6	FM-Canada Intrinsic Safety
I7	IECEx Intrinsic Safety
KA	ATEX Intrinsic Safety+FM-US Intrinsic Safety
KC	ATEX Intrinsic Safety+IECEx Intrinsic Safety
KD	FM-US Intrinsic Safety+FM-Canada Intrinsic Safety
NA	None
Custody Transfer Type Approval	
R ⁽³⁾⁽⁴⁾	OIML R85 E performance certification
C ⁽³⁾⁽⁵⁾	PTB Eich (German W&M approval)
N ⁽⁵⁾⁽⁶⁾	NMi (Dutch W&M approval)
A ⁽³⁾⁽⁴⁾	CMI (Czech W&M approval)
E ⁽³⁾⁽⁴⁾	TJA (Estonian W&M approval)
Y ⁽³⁾⁽⁴⁾	Justervesenet (Norwegian W&M approval)
M ⁽⁴⁾⁽⁶⁾	BMS (Belgian W&M approval)
W ⁽³⁾⁽⁴⁾	METAS (Swiss W&M approval)
0	None
Radar Measurement Method	
1	10 GHz FMCW radar technology
2	10 GHz FMCW radar technology for the US market
Housing	
A	Standard enclosure, polyurethane-covered aluminum. IP 66/67
Cable / Conduit Connections	
1	½ - 14 NPT, female thread. 1 plug included
2	M20 x 1.5 adapters, female thread. 2 adapters and 1 plug included
G	Metal cable glands (½ - 14 NPT). Min. temperature -20 °C (-4 °F). ATEX / IECEx Exe approved. 2 glands and 1 plug included
E	Eurofast male connector, 1 plug included
M	Minifast male connector, 1 plug included
Antenna	
1H	Horn antenna
Antenna Size	
8	8 in. / DN 200, Ø=175 mm (6.9 in.)

Table 2. 5900S Radar Level Gauge with horn antenna ordering information

Antenna Material	
S	Stainless steel (material type corresponding to AISI 316/316L and EN 1.4401 /1.4404)
Tank Seal	
PV	PTFE with Viton® fluoroelastomer o-ring
Tank Connection	
ANSI Hole Pattern (SST AISI 316 / 316 L) – Flat Face	
8A	8 in. Class 150
8Z	8 in. Class 150, 4° inclined
EN Hole Pattern (SST EN 1.4401 / 1.4404) – Flat Face	
LA	DN 200 / PN 10
LZ	DN 200 / PN 10, 4° inclined
Special	
0	None
Options (Include with selected model number)	
WR3	Extended Product Warranty: 3-year limited warranty
WR5	Extended Product Warranty: 5-year limited warranty
QT ⁽⁷⁾	IEC 61508 certificate and FMEDA-data
Q4	Calibration certificate
S4	Calibration certificate, witnessed by factory selected accredited third party
Q8 ⁽⁸⁾	Antenna material traceability certification per EN 10204 3.1
ST	Engraved SST tag plate
U1 ⁽⁹⁾	TÜV/DIBt WHG approval for overfill protection
Typical Model Number: 5900S P F 2 F I5 R 2 A G 1H 8 S PV 8Z 0 ST	

- (1) Requires Redundancy code 2 and Rosemount 2410 Tank Hub with Relay Output (SIS/SIL) code 3. Alarm if one of the two gauges is in alarm mode.
- (2) Requires Rosemount 2410 Tank Hub with Relay Output (SIS/SIL) code 2.
- (3) Requires Options code Q4.
- (4) Requires Rosemount 2410 Tank Hub with the corresponding Custody Transfer Type Approval. Integral 2410 display or Rosemount 2230 display or TankMaster required. Approval plate and sealing kit included.
- (5) Requires Rosemount 2410 Tank Hub with the corresponding Custody Transfer Type Approval. Integral 2410 display or Rosemount 2230 display (with corresponding type approval) or TankMaster required. Approval plate and sealing kit included.
- (6) Requires Options code S4
- (7) Requires Safety Certification (SIS) code 2 or 3.
- (8) Certificate includes all pressure retaining wetted parts.
- (9) Requires one or more relay outputs in the Rosemount 2410 Tank Hub.

Rosemount 5900S radar level gauge with still-pipe array antenna



The Rosemount 5900S with array antenna is a premium non-contact radar level gauge for still-pipe measurement, available in two versions, Fixed and Hinged Hatch. Typical applications are crude oil tanks with floating roofs and gasoline/product tanks with or without inner floating roofs.

- Suitable for crude oil, gasoline or similar products
- Custody transfer accuracy according to OIML R85:2008
- Certified SIL 2 and SIL 3 capable according to IEC 61508
- 2-in-1 functionality available for redundant level measurement
- Tolerant against rust and product deposits inside the pipe
- Communicates via a 2-wire, low voltage Tankbus for easy and safe installation
- Hinged hatch version enables easier product sampling and hand-dips
- Installation normally with tank in service

Table 3. 5900S Radar Level Gauge with still-pipe array antenna ordering information

Model	Product Description
5900S	Radar Level Gauge
Performance Class	
P	Premium: ± 0.5 mm (0.020 in.) instrument accuracy
Safety Certification (SIS)	
3 ⁽¹⁾	Certified IEC 61508 SIL 3 capable
2 ⁽²⁾	Certified IEC 61508 SIL 2 capable
F	None. Ready for upgrade of safety certification (SIS)
0	None
Redundancy	
2	2-in-1; Independent radar level gauge electronics
F	None. Ready for upgrade to 2-in-1
1	None. Single radar level gauge electronics
Tankbus: Power and Communication	
F	Bus powered 2-wire FOUNDATION™ fieldbus (IEC 61158)

Table 3. 5900S Radar Level Gauge with still-pipe array antenna ordering information

Hazardous Location Certification	
I1	ATEX Intrinsic Safety
I2	Brazil Inmetro Intrinsic Safety
I5	FM-US Intrinsic Safety
I6	FM-Canada Intrinsic Safety
I7	IECEX Intrinsic Safety
KA	ATEX Intrinsic Safety+FM-US Intrinsic Safety
KC	ATEX Intrinsic Safety+IECEX Intrinsic Safety
KD	FM-US Intrinsic Safety+FM-Canada Intrinsic Safety
NA	None
Custody Transfer Type Approval	
R ⁽³⁾⁽⁴⁾	OIML R85 E performance certification
C ⁽³⁾⁽⁵⁾	PTB Eich (German W&M approval)
N ⁽⁵⁾⁽⁶⁾	NMi (Dutch W&M approval)
A ⁽³⁾⁽⁴⁾	CMI (Czech W&M approval)
E ⁽³⁾⁽⁴⁾	TJA (Estonian W&M approval)
Y ⁽³⁾⁽⁴⁾	Justervesenet (Norwegian W&M approval)
M ⁽⁴⁾⁽⁶⁾	BMS (Belgian W&M approval)
W ⁽³⁾⁽⁴⁾	METAS (Swiss W&M approval)
0	None
Radar Measurement Method	
1	10 GHz FMCW radar technology
2	10 GHz FMCW radar technology for the US market
Housing	
A	Standard enclosure, polyurethane-covered aluminum. IP 66/67
Cable / Conduit Connections	
1	½ - 14 NPT, female thread. 1 plug included
2	M20 x 1.5 adapters, female thread. 2 adapters and 1 plug included
G	Metal cable glands (½ - 14 NPT). Min. temperature -20 °C (-4 °F). ATEX / IECEX Exe approved. 2 glands and 1 plug included
E	Eurofast male connector, 1 plug included
M	Minifast male connector, 1 plug included
Antenna	
1A	Still-pipe array antenna

Table 3. 5900S Radar Level Gauge with still-pipe array antenna ordering information

Antenna Size	
5	5 in. / DN 125, Ø=120 mm (4.7 in.)
6	6 in. / DN 150, Ø=145 mm (5.7 in.)
8	8 in. / DN 200, Ø=189 mm (7.4 in.)
A	10 in. / DN 250, Ø=243 mm (9.8 in.)
B	12 in. / DN 300, Ø=293 mm (11.8 in.)
Antenna Material	
S	Stainless steel (AISI 316L / EN 1.4404) and PPS (Polyphenylene sulfide)
Tank Seal	
FF	Fixed flange installation with fluorosilicone o-ring
HH	Integrated hatch installation with fluorosilicone o-ring
Tank Connection	
ANSI Hole Pattern (SST AISI 316 L) – Flat Face	
5A	5 in. Class 150
6A	6 in. Class 150
8A	8 in. Class 150
AA	10 in. Class 150
BA	12 in. Class 150
EN Hole Pattern (SST EN 1.4404) – Flat Face	
KA	DN 150 PN 16
LA	DN 200 PN 10
MB	DN 250 PN 16
Special	
0	None
C	Clamp flange in galvanized steel (for still-pipes without a flange). Same size as tank connection
√(7)(8)	Proof test reflector kit (size equal to tank connection)

Table 3. 5900S Radar Level Gauge with still-pipe array antenna ordering information

Options (Include with selected model number)	
WR3	Extended Product Warranty: 3-year limited warranty
WR5	Extended Product Warranty: 5-year limited warranty
QT ⁽⁹⁾	IEC 61508 certificate and FMEDA-data
Q4	Calibration certificate
S4	Calibration certificate, witnessed by factory selected accredited third party
Q8 ⁽¹⁰⁾	Antenna material traceability certification per EN 10204 3.1
ST	Engraved SST tag plate
U1 ⁽¹¹⁾	TÜV/DIBt WHG approval for overfill protection
Typical Model Number: 5900S P F 1 F I5 R 2 A 1 1A 5 S FF AA C Q4	

- (1) Requires Redundancy code 2 and Rosemount 2410 Tank Hub with Relay Output (SIS/SIL) code 3. Alarm if one of the two gauges is in alarm mode.
- (2) Requires Rosemount 2410 Tank Hub with Relay Output (SIS/SIL) code 2.
- (3) Requires Options code Q4.
- (4) Requires Rosemount 2410 Tank Hub with the corresponding Custody Transfer Type Approval. Integral 2410 display or Rosemount 2230 display or TankMaster required. Approval plate and sealing kit included.
- (5) Requires Rosemount 2410 Tank Hub with the corresponding Custody Transfer Type Approval. Integral 2410 display or Rosemount 2230 display (with corresponding type approval) or TankMaster required. Approval plate and sealing kit included.
- (6) Requires Options code S4
- (7) Requires Custody Transfer Type Approval code 0 or R, and Antenna Size 6 or 8
- (8) Not available with Options code U1.
- (9) Requires Safety Certification (SIS) code 2 or 3.
- (10) Certificate includes all pressure retaining wetted parts.
- (11) Requires one or more relay outputs in the Rosemount 2410 Tank Hub.

Rosemount 5900S radar level gauge with LPG/LNG antenna

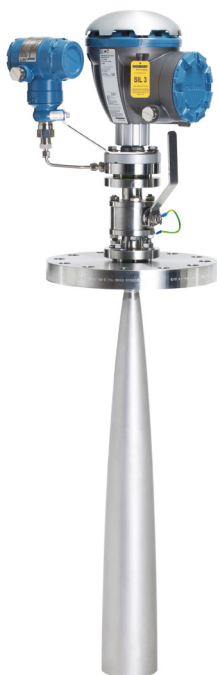

The Rosemount 5900S with LPG/LNG antenna is a premium non-contact radar level gauge for measurement on pressurized or cryogenic liquefied gas. Radar signals are transmitted inside the still-pipe which enables the gauge to have a sufficiently strong echo even under surface boiling conditions.

- Custody transfer accuracy according to OIML R85:2008
- Certified SIL 2 and SIL 3 capable according to IEC 61508
- 2-in-1 functionality available for redundant level measurement
- Reference device function enables measurement verification with the tank in service
- Communicates via a 2-wire, low voltage Tankbus for easy and safe installation
- Built-in pressure sensor for vapor compensation gives best measurement performance
- Integrated ball valve

Table 4. 5900S Radar Level Gauge with LPG/LNG antenna ordering information

Model	Product Description
5900S	Radar Level Gauge
Performance Class	
P	Premium: ± 0.5 mm (0.020 in.) instrument accuracy
Safety Certification (SIS)	
3 ⁽¹⁾	Certified IEC 61508 SIL 3 capable
2 ⁽²⁾	Certified IEC 61508 SIL 2 capable
F	None. Ready for upgrade of safety certification (SIS)
0	None
Redundancy	
2	2-in-1; Independent radar level gauge electronics
F	None. Ready for upgrade to 2-in-1
1	None. Single radar level gauge electronics
Tankbus: Power and Communication	
F	Bus powered 2-wire FOUNDATION™ fieldbus (IEC 61158)

Table 4. 5900S Radar Level Gauge with LPG/LNG antenna ordering information

Hazardous Location Certification	
I1	ATEX Intrinsic Safety
I2	Brazil Inmetro Intrinsic Safety
I5	FM-US Intrinsic Safety
I6	FM-Canada Intrinsic Safety
I7	IECEx Intrinsic Safety
KA	ATEX Intrinsic Safety+FM-US Intrinsic Safety
KC	ATEX Intrinsic Safety+IECEx Intrinsic Safety
KD	FM-US Intrinsic Safety+FM-Canada Intrinsic Safety
NA	None
Custody Transfer Type Approval	
R ⁽³⁾⁽⁴⁾	OIML R85 E performance certification
C ⁽³⁾⁽⁵⁾	PTB Eich (German W&M approval)
N ⁽⁵⁾⁽⁶⁾	NMi (Dutch W&M approval)
A ⁽³⁾⁽⁴⁾	CMI (Czech W&M approval)
E ⁽³⁾⁽⁴⁾	TJA (Estonian W&M approval)
Y ⁽³⁾⁽⁴⁾	Justervesenet (Norwegian W&M approval)
M ⁽⁴⁾⁽⁶⁾	BMS (Belgian W&M approval)
W ⁽³⁾⁽⁴⁾	METAS (Swiss W&M approval)
0	None
Radar Measurement Method	
1	10 GHz FMCW radar technology
2	10 GHz FMCW radar technology for the US market
Housing	
A	Standard enclosure, polyurethane-covered aluminum. IP 66/67

Table 4. 5900S Radar Level Gauge with LPG/LNG antenna ordering information

Cable / Conduit Connections	
1	½ - 14 NPT, female thread. 1 plug included
2	M20 x 1.5 adapters, female thread. 2 adapters and 1 plug included
G	Metal cable glands (½ - 14 NPT). Min. temperature -20 °C (-4 °F). ATEX / IECEx Exe approved. 2 glands and 1 plug included
E	Eurofast male connector, 1 plug included
M	Minifast male connector, 1 plug included
Antenna	
G1 ⁽⁷⁾	LNG still-pipe antenna
G2 ⁽⁸⁾⁽⁹⁾	LPG still-pipe antenna
Antenna Size	
A	4 in. Schedule 10, Ø=107 mm (4.2 in.)
B	4 in. Schedule 40, Ø=101 mm (4.0 in.)
D	DN 100, Ø=99 mm (3.9 in.)
Antenna Material	
S	Stainless steel (material type corresponding to AISI 316/316L and EN 1.4401 /1.4404)
Tank Seal	
QA	Quartz sealing
Tank Connection	
ANSI Flanges (SST AISI 316 L) – Raised Face	
4A	4 in. Class 150
4B	4 in. Class 300
6A	6 in. Class 150
6B	6 in. Class 300
8A	8 in. Class 150
8B	8 in. Class 300
Special	
V	Measurement verification kit with 1 verification pin and 1 pipe end deflector kit

Table 4. 5900S Radar Level Gauge with LPG/LNG antenna ordering information

Options (Include with selected model number)	
WR3	Extended Product Warranty: 3-year limited warranty
WR5	Extended Product Warranty: 5-year limited warranty
QT ⁽¹⁰⁾	IEC 61508 certificate and FMEDA-data
Q4	Calibration certificate
S4	Calibration certificate, witnessed by factory selected accredited third party
Q8 ⁽¹¹⁾	Antenna material traceability certification per EN 10204 3.1
ST	Engraved SST tag plate
P1	Antenna hydrostatic pressure testing
U1 ⁽¹²⁾	TÜV/DIBt WHG approval for overfill protection
Typical Model Number: 5900S P F 2 F I5 R 2 A M G1 B S QA 4A V Q4	

- (1) Requires Redundancy code 2 and Rosemount 2410 Tank Hub with Relay Output (SIS/SIL) code 3. Alarm if one of the two gauges is in alarm mode.
- (2) Requires Rosemount 2410 Tank Hub with Relay Output (SIS/SIL) code 2.
- (3) Requires Options code Q4.
- (4) Requires Rosemount 2410 Tank Hub with the corresponding Custody Transfer Type Approval. Integral 2410 display or Rosemount 2230 display or TankMaster required. Approval plate and sealing kit included.
- (5) Requires Rosemount 2410 Tank Hub with the corresponding Custody Transfer Type Approval. Integral 2410 display or Rosemount 2230 display (with corresponding type approval) or TankMaster required. Approval plate and sealing kit included.
- (6) Requires Options code S4
- (7) Including integrated ball valve.
- (8) Including integrated ball valve and pressure transmitter.
- (9) Requires Hazardous Location Certification code I1, I2, I5, I6 or I7.
- (10) Requires Safety Certification (SIS) code 2 or 3.
- (11) Certificate includes all pressure retaining wetted parts.
- (12) Requires one or more relay outputs in the Rosemount 2410 Tank Hub.

Specifications

Instrument accuracy⁽¹⁾

± 0.5 mm (0.020 in.)

Temperature stability

Typically < ± 0.5 mm (0.020 in.) in -40 to +70 °C (-40 to +158 °F)

Fieldbus (standard)

FOUNDATION™ fieldbus FISCO (Tankbus)

Update time

New measurement every 0.3 s

Repeatability

0.2 mm (0.008 in.)

Maximum level rate

Up to 200 mm/s

Metrology sealing possibility

Yes

Installation considerations

See Rosemount 5900S Reference Manual

Measurement principle

The FMCW-method (Frequency Modulated Continuous Wave) means that the transmitted radar signal has a linear frequency variation around 10 GHz. The reflection from the liquid surface has a slightly different frequency compared with the signal transmitted from the antenna when the reflection is received. The difference in frequency is directly proportional to the distance between the antenna and the liquid surface, and thereby also the liquid level. This technology enables a very accurate and stable measured value.

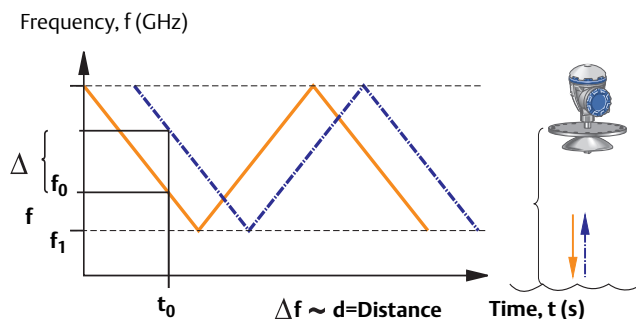

The FMCW-method is based on a radar sweep with varying frequency.

Communication / Display / Configuration

Output variables and units

- Level, and ullage: meter, centimeter, millimeter, feet, or inch
- Level rate: meter/second, meter/hour, feet/second, feet/hour, inch/minute
- Signal strength: mV

Configuration tools

Rosemount TankMaster WinSetup, Field Communicator

FOUNDATION™ fieldbus characteristics

Polarity sensitive

No

Quiescent current draw

51 mA

Lift-off minimum voltage

9.0 VDC

Device capacitance / inductance

See Product Certification on [page 23](#)

Class (Basic or Link Master)

Link Master (LAS)

Number of available VCRs

Maximum 20, including one fixed

Links

Maximum 40

Minimum slot time / maximum response delay / minimum intermessage delay

8/5/8

(1) Instrument accuracy is under reference conditions. Reference conditions are: Measurement in test bench at Rosemount Tank Radar AB in Göteborg Sweden. Test bench is calibrated minimum yearly by an accredited laboratory (SP Technical Research Institute of Sweden. Measuring range is up to 30 m (98 ft). Ambient temperature and humidity is close to constant during tests. Total uncertainty in test bench is below 0.15 mm (0.006 in.).

Blocks and Execution time

1 Resource block.
 5 Transducer blocks (Level, Register, Adv_Config, Volume, and LPG).
 6 Analog Input (AI) blocks: 10 ms, 2 Analog Output (AO) blocks: 10 ms.
 1 Proportional/Integral/Derivate (PID) block: 15 ms
 1 Signal Characterizer (SGCR) block: 10 ms, 1 Integrator (INT) block: 10 ms,
 1 Arithmetic (ARTH) block: 10 ms, 1 Input Selector (ISEL) block: 10 ms.
 1 Control Selector (CS) block: 10 ms, 1 Output Splitter (OS) block: 10 ms.
 For more information, see the FOUNDATION™ fieldbus Blocks manual (document number 00809-0100-4783).

Instantiation

Yes

Conforming FOUNDATION™ fieldbus

ITK 5.2

PlantWeb alert support

Yes

Action support wizards

Restart measurement, write protect device, factory reset - measurement configuration, start/stop device simulation, set as surface, reset statistics, change all modes, register/remove false echo, refresh echo peaks, pin verification, change vapor pressure, change vapor temperature.

Advanced diagnostics

Software, memory/database, electronics, internal communication, simulation, level correction, level measurement, ambient temperature, vapor pressure/temperature correction, LPG verification pin, and manual measurement values.

Electric

Tankbus cabling

0.5-1.5 mm² (AWG 22-16), twisted shielded pairs

Power supply

FISCO: 9.0 - 17.5 VDC polarity insensitive (for example from 2410 Tank Hub)
 Entity: 9.0 - 30.0 VDC polarity insensitive

Bus current draw

50 mA (100 mA for the 2-in-1 version)

Microwave output power

< 1 mW

Mechanical

Housing material & surface treatment

Polyurethane-coated die-cast aluminum

Cable entry (connection/glands)

Two ½ - 14 NPT entries for cable glands or conduits. One metal plug to seal any unused port is enclosed in the transmitter delivery.

Optional:

- M20 x 1.5 conduit / cable adapter
- Cable glands in metal (½ - 14 NPT)
- 4-pin male Eurofast connector or A size Mini 4-pin male Minifast connector

Total weight

- 5900S transmitter head: 5.1 kg (11.2 lbs) for the single version and 5.4 kg (11.9 lbs) for the 2-in-1 version
- 5900S with horn antenna: Appr. 12 kg (26 lbs)
- 5900S with parabolic antenna: Appr. 17 kg (37 lbs)
- 5900S with still-pipe array antenna: Appr. 13.5-24 kg (30-53 lbs)
- 5900S with LPG/LNG antenna: Appr. 30 kg (66 lbs) for 6-in. 150 psi, and 40 kg (88 lbs) for 6-in. 300 psi

Antennas

The 5900S antennas have a drip-off design which for some versions also include inclined polished PTFE surfaces. Condensation on the antenna is minimized, and the radar signal remains strong. This results in maintenance free operation, high accuracy and reliability. There is always a suitable antenna for every tank type, tank opening and application.

Transmitter head

The same transmitter head is used for all 5900S antenna types, minimizing spare part requirements:

- The dual compartment transmitter housing, with electronics and cabling separated, can be replaced without opening the tank
- It is protected against lightning, moisture/rain, and has a surface protection against sulphur and salt spray atmospheres
- Electronics consists of one or two encapsulated units. The 2-in-1 solution has duplicate, galvanically isolated electronic units in the same housing

To achieve highest precision, 5900S has an on-line adjustment of transmitter frequency. It uses a crystal oscillator to control the output frequency. This is one of the reasons why there is no need for gauge re-calibration.

Environment

Ambient operating temperature

-40 to +70 °C (-40 to +158 °F). Minimum start-up temperature is -50 °C (-58 °F)

Storage temperature

-50 to +85 °C (-58 to +185 °F)

Humidity

0-100% relative humidity

Ingress protection

IP 66/67 and Nema 4X

Vibration resistance

IEC 60770-1 level 1 and IACS UR E10 test 7

Telecommunication

Compliance with:

- FCC 15B Class A, and 15C
- R&TTE (EU directive 99/5/EC) ETSI EN 302372; EN 50371
- IC (RSS210-5)

Electromagnetic compatibility

- EMC (EU directive 2004/108/EC) EN 61326-1; EN 61326-3-1
- OIML R85:2008

Transient / built-in lightning protection

According to IEC 61000-4-5, level 2 kV line to ground. Complies with IEEE 587 Category B transient protection and IEEE 472 surge protection.

Pressure Equipment Directive (PED)

97/23/EC

Low Voltage Directive (LVD)

LVD (EU directive 2006/95/EC) EN/IEC 61010-1

5900S standard version

Built-in Tankbus terminator

Yes (to be connected if required)

Daisy chain possibility

Yes

5900S 2-in-1 version

Instrument accuracy⁽¹⁾

± 0.5 mm (0.020 in.)⁽²⁾

Separation

Galvanically separated gauge electronics, and shared antenna for the two units

Wiring

Separated or common

Tank hub connection

- Connection of both units to one hub, or
- Separate connection of units to two different hubs

Built-in Tankbus terminator

Single Tankbus connection: Yes (to be connected if required).
Dual Tankbus connection: Possible to terminate the primary Tankbus.

Daisy chain possibility

Yes

5900S SIL version

Separation

Galvanically separated gauge electronics, and shared antenna for the SIL 3 version

Built-in Tankbus terminator

No

Daisy chain possibility

Yes

Electric properties for intrinsically safe alarm signal

12.5 VDC, 1-2 mA for normal condition (no alarm)

Wiring

- Additional separate 2-wire cable for alarm or
- A single cable incorporating two 2-wire cables (alarm and level)

For cable specification, see [page 19](#).

(1) Instrument accuracy is under reference conditions. Reference conditions are: Measurement in test bench at Rosemount Tank Radar AB in Göteborg Sweden. Test bench is calibrated minimum yearly by an accredited laboratory (SP Technical Research Institute of Sweden. Measuring range is up to 30 m (98 ft). Ambient temperature and humidity is close to constant during tests. Total uncertainty in test bench is below 0.15 mm (0.006 in.).

(2) Some degradation of accuracy may be expected on the secondary unit.

5900S with parabolic antenna

Operating temperature in tank

Max. +230 °C (+445 °F)

Measuring range

0.8 to 30 m (2.6 to 100 ft) below flange.
Possibility to measure 0.5 to 50 m (1.6 to 164 ft). Accuracy may be reduced. For longer measuring range, please consult your local representative.

Pressure range

Clamped/threaded: -0.2 to 0.2 bar (-2.9 to 2.9 psig)
Welded: -0.2 to 10 bar (-2.9 to 145 psig)

Material exposed to tank atmosphere

Antenna: material corresponds to AISI 316/316L and EN 1.4401 /1.4404.

Sealing: PTFE

O-ring: FEP fluoropolymer

Antenna dimension

440 mm (17 in.)

Manway size and installation

500 mm (20-in.) opening.

The parabolic antenna is installed on the manway cover by using the flange ball. It is designed for easy adjustment of the antenna inclination and orientation within the specified limits.

The flexible flange ball can be installed on both horizontal or inclined manways without any special arrangements.

5900S with horn antenna

Operating temperature in tank

Max. +230 °C (+445 °F)

Measuring range

0.8 to 20 m (2.6 to 65 ft) below flange.
Possibility to measure 0.5 to 30 m (1.6 to 100 ft). Accuracy may be reduced.

Pressure range

-0.2 to 2 bar (-2.9 to 29 psig)

Material exposed to tank atmosphere

Antenna and flange: material corresponds to AISI 316/316L and EN 1.4401 /1.4404.

Sealing: PTFE

O-ring: Viton® fluoroelastomer

Antenna dimension

175 mm (7 in.)

Nozzle diameter

Minimum 200 mm (8 in.)

Tank connection

The flange can be horizontal or 4° inclined for installation close to the tank wall.

The horizontal flange is used when highest accuracy and reliability is required. The 4° inclined version can be used to maintain high accuracy when the gauge is installed close to the tank wall.

5900S with still-pipe array antenna

Operating temperature in tank

-40 to 120 °C (-40 to 248 °F)

Measuring range

0.8 to 30 m (2.6 to 100 ft) below flange.
Possibility to measure 0.5 to 40 m (1.6 to 130 ft). Accuracy may be reduced. For longer measuring range, please consult your local representative.

Pressure range

Fixed version: -0.2 to 2 bar (-2.9 to 29 psig) at 20 °C (68 °F).
Hinged hatch version: -0.2 to 0.5 bar (-2.9 to 7.2 psig) for 5 to 8-in. pipes.
-0.2 to 0.25 bar (-2.9 to 3.6 psig) for 10 and 12-in. pipes.

Material exposed to tank atmosphere

Antenna: Polyphenylenesulphide (PPS)
Sealing: PTFE
O-ring: Fluorosilicone
Flange: material corresponds to AISI 316/316L and EN 1.4401 / 1.4404

Still-pipe dimensions

5-, 6-, 8-, 10- or 12 in.

Tank connection

5 in. hole pattern according to ANSI 5 in. Class 150
6 in. hole pattern according to ANSI 6 in.
Class 150 / DN 150 PN 16
8 in. hole pattern according to ANSI 8 in.
Class 150 / DN 200 PN 10
10 in. hole pattern according to ANSI 10 in.
Class 150 / DN 250 PN 16
12 in. hole pattern according to ANSI 12 in. Class 150

Low Loss Mode

To get the accuracy, required for custody transfer bulk liquid storage applications, the antenna uses Low Loss Mode technology, invented for Rosemount Tank Gauging products, to transmit radar waves in the still-pipe center.

This virtually eliminates signal and accuracy degradation due to rust and product deposits inside the still-pipe.

5900S with LPG/LNG antenna

Operating temperature at ball valve

-55 to 90 °C (-67 to 194 °F)

Operating temperature in tank

-170 to 90 °C (-274 to 194 °F)

Measuring range

1.2 to 30 m (3.9 to 100 ft) below flange.
Possibility to measure 0.8 to 60 m (2.6 to 200 ft). Accuracy may be reduced. For longer measuring range, please consult your local representative.

Pressure range

-1 to 25 bar (-14.5 to 365 psig).
Note! Flanges may have higher pressure rating than 25 bar, but maximum tank pressure is still 25 bar.

Pressure sensor (option)

Rosemount 2051. It is available with various hazardous location certifications, see [page 25](#).
For more information see the 2051 Product Data Sheet (document number 00813-0100-4101).

Material exposed to tank atmosphere

Antenna and flange: material corresponds to AISI 316/316L and EN 1.4401 / 1.4404.
Sealing: Quartz and PTFE

Still-pipe dimension compatibility

Antenna choices for 4-in. sch. 10, 4-in. sch 40, or 100 mm (99 mm inner diameter) still-pipe dimensions

Flange size & rating

4 in. class 150/300
6 in. class 150/300
8 in. class 150/300

Pressure seal

The pressure seal includes a double-block function, consisting of a quartz/ceramic window and a fire-proof ball valve. A pressure sensor enables correction due to vapor for best measurement performance.

Verification possibility

A patented reference device function enables measurement verification with the tank in service. A verification pin mounted in a still-pipe hole, and a deflection plate with a verification ring at the lower still-pipe end provide reference echoes at fixed pre-defined distances.

Product Certifications

OIML R85:2008 Accuracy Certification

The OIML metrology certificate, issued by the SP Technical Research Institute of Sweden, covers the Rosemount Tank Gauging system, including the level gauges equipped with different antennas.

Certificate number is R85/2008-SE-11.01.



National Metrological Approvals

Other national legal custody transfer certifications like PTB, NMI etc are available (see "Ordering information" on page 4).

CE-mark

93/68/EEC: complies with applicable EU directives (EMC, ATEX, LVD, and R&TTE). Based on the low emitted effects from the gauges (below 0.1 mW) compared to limits given by the Rec. 1999/519/EC, no additional measures are needed.

Ordinary Location Certification

Complies with FM 3810:2005 and CSA: C22.2 No. 1010.1

SIL Certification

The SIL safety certificate, issued by exida in Switzerland, includes the SIL alarm channel within the 5900S radar level gauge and the 2410 Tank Hub. Both units are SIL 2 and SIL 3 capable according to IEC 61508, parts 1-7.

Certificate number is Rosemount 091243 P0017 C001.



German WHG Certification

The certificate for the 5900S radar level gauge and the 2410 Tank Hub is issued by DIBt (Deutsches Institut für Bautechnik) according to the German WHG regulations for overfill prevention. It is based on technical evaluation and testing conducted by TÜV NORD CERT GmbH.

Certificate number is Z-65.16-500.



Hazardous Location Certificates

European ATEX Directive Information

EC-Type Examination Certificate Number: FM09ATEX0057X
Control Drawing: 9240 040-917

I1⁽¹⁾ Intrinsically Safe:

FISCO Field Device:

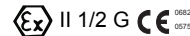

Ex ia IIC T4 (-50 °C < T_a < +80 °C)

For each channel: U_i=17.5 VDC, I_i=380 mA, P_i=5.32 W,

C_i=1.1 nF, L_i=1.5 μH

Entity:

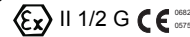

Ex ia IIC T4 (-50 °C < T_a < +80 °C)

For each channel: U_i=30 VDC, I_i=300 mA, P_i=1.3 W,

C_i=1.1 nF, L_i=1.5 μH

SPECIAL CONDITIONS FOR SAFE USE (X)

1. The enclosure contains aluminum and is considered to present a potential risk of ignition by impact or friction. Care must be taken during installation and use to prevent impact or friction.
2. Parabolic and Array antennas with plastic surfaces and the painted surface of the enclosure may, under certain extreme conditions, generate an ignition-capable level of electrostatic charge for IIC applications. Therefore, when these antennas are used in Category 1G, Group IIC, appropriate measures must be taken to prevent electrostatic discharge.
3. Category 1/2 notation: The Rosemount 5900 Radar Level Gauge was evaluated so that an [ib] associated apparatus can connect to it restricting the installation of the electronics to a Zone 1 location while still allowing the antenna to enter a Zone 0 location.

(1) Ordering Information code for Hazardous Location Certification.

US Factory Mutual (FM-US) Certification

Certificate of Compliance: 3035466
Control Drawing: 9240 040-917

I5⁽¹⁾ Intrinsically Safe

FISCO Field Device:
Intrinsically Safe for Class I, II, III, Division 1, Groups A, B, C,
D, E, F, and G
Class I, Zone 0/1 AEx ia IIC

For each channel: $U_i=17.5$ VDC, $I_i=380$ mA, $P_i=5.32$ W,
 $C_i=1.1$ nF, $L_i=1.5$ μ H

Entity:
Intrinsically Safe for Class I, II, III, Division 1, Groups A, B, C,
D, E, F, and G
Class I, Zone 0/1 AEx ia IIC

For each channel: $U_i=30$ VDC, $I_i=300$ mA, $P_i=1.3$ W,
 $C_i=1.1$ nF, $L_i=1.5$ μ H
Dust ignition proof for Class II/III, Division 1, Groups E, F,
and G
Temperature Code T4
Ambient Temperature Limits: -50 to +80 °C

SPECIAL CONDITIONS OF USE

1. Parabolic and Array antennas with plastic surfaces and the surface of the painted housing may, under certain extreme conditions, generate an ignition-capable level of electrostatic charge. Appropriate measures must be taken to prevent electrostatic discharge.
2. Class I, Zone 0/1 notation: For installation in Zone classified locations, the Rosemount 5900 Radar Level Gauge was evaluated so that an [ib] associated apparatus can connect to it restricting the installation of the electronics to a Zone 1 location while still allowing the antenna to enter a Zone 0 location.

Canadian Factory Mutual (FM-C) Certification

Certificate of Compliance: 3035466C
Control Drawing: 9240 040-917

I6⁽¹⁾ Intrinsically Safe

FISCO Field Device:
Intrinsically Safe for Class I, II, III, Division 1, Groups A, B, C,
D, E, F, and G.
Ex ia IIC
For each channel: $U_i=17.5$ VDC, $I_i=380$ mA, $P_i=5.32$ W,
 $C_i=1.1$ nF, $L_i=1.5$ μ H

Entity:
Intrinsically Safe for Class I, II, III, Division 1, Groups A, B, C,
D, E, F, and G.
Ex ia IIC
For each channel: $U_i=30$ VDC, $I_i=300$ mA, $P_i=1.3$ W,
 $C_i=1.1$ nF, $L_i=1.5$ μ H
Dust ignition proof for Class II/III, Division 1, Groups E, F,
and G
Temperature Code T4
Ambient Temperature Limits: -50 to +80 °C

SPECIAL CONDITIONS OF USE

1. Parabolic and Array antennas with plastic surfaces and the surface of the painted housing may, under certain extreme conditions, generate an ignition-capable level of electrostatic. Appropriate measures must be taken to prevent electrostatic discharge.

IECEx Certification

Certificate of Conformity Number: IECEx FMG 09.0009X
Control Drawing: 9240 040-917

I7⁽¹⁾ Intrinsically Safe

FISCO Field Device:
Ex ia IIC T4 Ga/Gb (-50 °C < T_a < +80 °C)
For each channel: $U_i=17.5$ VDC, $I_i=380$ mA, $P_i=5.32$ W,
 $C_i=1.1$ nF, $L_i=1.5$ μ H

Entity:
Ex ia IIC T4 Ga/Gb (-50 °C < T_a < +80 °C)
For each channel: $U_i=30$ VDC, $I_i=300$ mA, $P_i=1.3$ W,
 $C_i=1.1$ nF, $L_i=1.5$ μ H

(1) Ordering Information code for Hazardous Location Certification.

SPECIAL CONDITIONS OF CERTIFICATION (X):

1. The enclosure contains aluminum and is considered to present a potential risk of ignition by impact or friction. Care must be taken during installation and use to prevent impact or friction.
2. Parabolic and Array antennas with plastic surfaces and the painted surface of the enclosure may, under certain extreme conditions, generate an ignition-capable level of electrostatic charge for IIC applications. Therefore, when these antennas are used in Category EPL Ga, Group IIC, appropriate measures must be taken to prevent electrostatic discharge.
3. Ga/Gb notation: The Rosemount 5900 Radar Level Gauge was evaluated so that an [ib] associated apparatus can connect to it restricting the installation of the electronics to a Zone 1 location while still allowing the antenna to enter a Zone 0 location.

Combination Approvals

The radar level gauge can be ordered with dual certifications (indicated at the main label). The following combinations are possible:

KA=I1+I5 (ATEX + FM-US)

KC=I1+I7 (ATEX +IECEx)

KD=I5+I6 (FM-US+FM-C)

Product Certifications Rosemount 2051**European ATEX Directive Information**

IA⁽¹⁾ FISCO Intrinsic Safety

Certification No. Baseefa08ATEX0129X  II 1 G

Ex ia IIC T4 (T_{amb} = -60 to +60 °C)

IP66

 1180

Input Parameters: U_i=17.5 VDC, I_i=380 mA, P_i=5.32 W, C_i ≤5 μF, L_i=10 μH.

SPECIAL CONDITIONS FOR SAFE USE (X):

The device is not capable of withstanding the 500V insulation test required by Clause 6.3.12 of EN60079-11.

This must be taken into account when installing the apparatus.

US Factory Mutual (FM-US) Certification

IE⁽¹⁾ Intrinsically Safe for use in Class I, Division 1, Groups A, B, C, and D; Class II, Division 1, Groups E, F, and G; Class III, Division 1 when connected per Rosemount drawing 02051-1009; Non-incendive for Class I, Division 2, Groups A, B, C, and D.

Temperature Code:T4 (T_a = 40 °C), T3 (T_a = 85 °C)

Enclosure Type 4X

For input parameters see control drawing 02051-1009.

Canadian Factory Mutual (FM-C) Certification

IF⁽¹⁾ Intrinsically safe approval. Intrinsically safe for Class I, Division 1, Groups A, B, C, and D when connected in accordance with Rosemount drawings 02051-1008. Temperature Code T3C.

Dust-Ignition-Proof for Class II and Class III, Division 1, Groups E, F, and G. Suitable for Class I, Division 2 Groups A, B, C, and D hazardous locations. Enclosure type 4X, factory sealed.

For input parameters see control drawing 02051-1008.

IECEx Certification

IA⁽¹⁾ FISCO Intrinsic Safety

Certification No. IECExBAS08.0045X  II 1 G

Ex ia IIC T4 (T_{amb} = -60 to +60 °C)

IP66

 1180

Input Parameters: U_i=17.5 VDC, I_i=380 mA, P_i=5.32 W, C_i ≤5 μF, L_i=10 μH.

SPECIAL CONDITIONS FOR SAFE USE (X):

The device is not capable of withstanding the 500V insulation test required by Clause 6.3.12 of EN60079-11.

This must be taken into account when installing the apparatus.

(1) Ordering Information code for Product Certificates

Dimensional Drawings

Figure 1. Dimensions for Rosemount 5900S with parabolic antenna dimensions

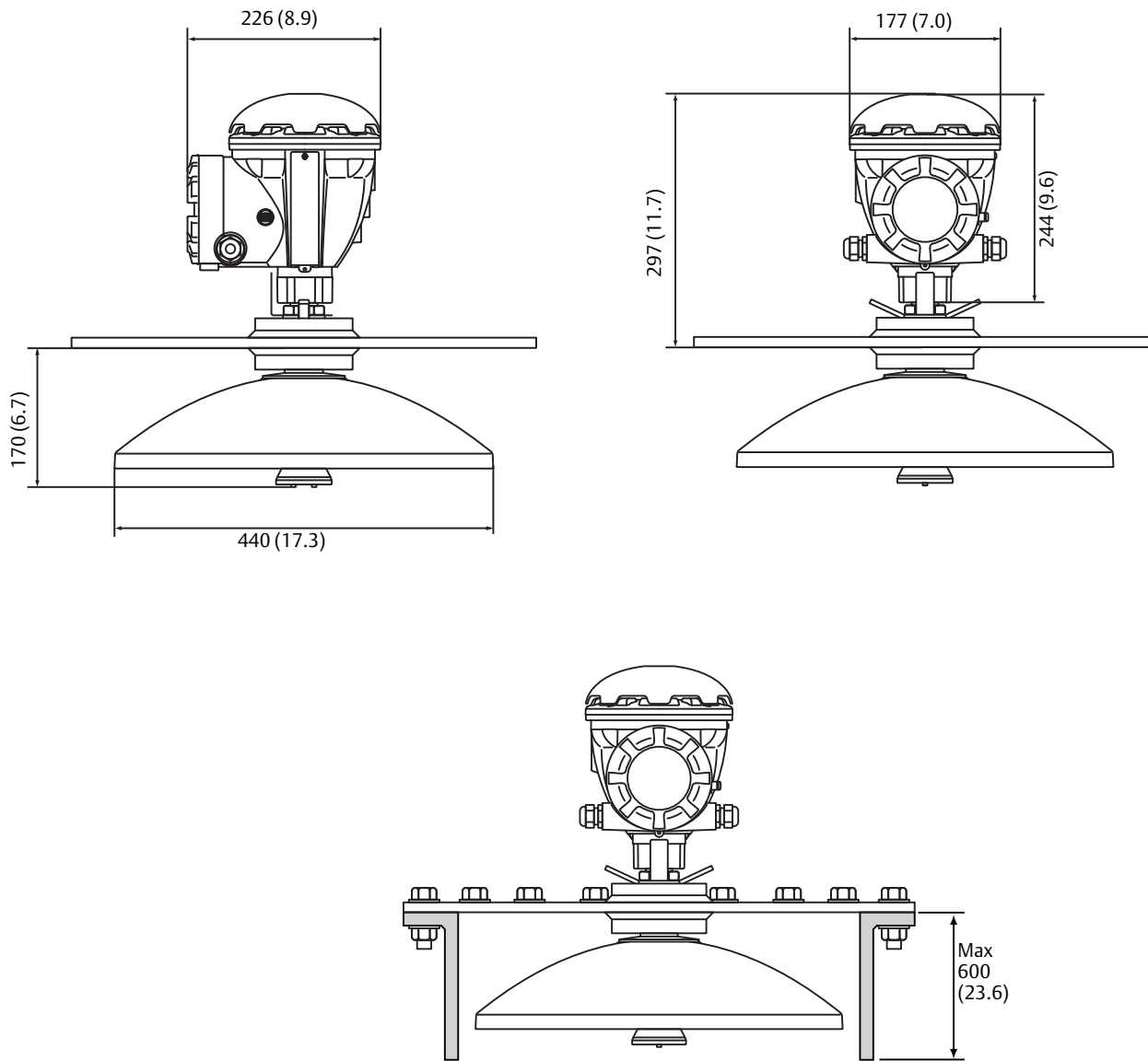

Note
Dimensions are in millimeters (inches).

Figure 2. Rosemount 5900S with horn antenna dimensions

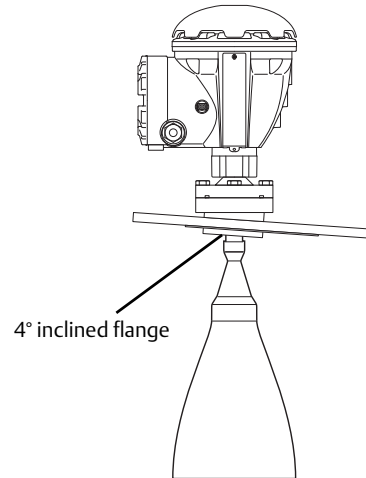
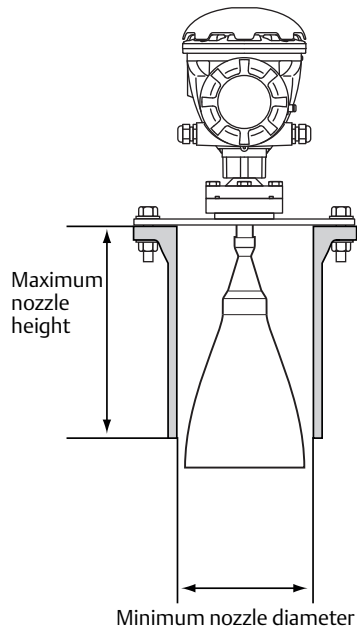
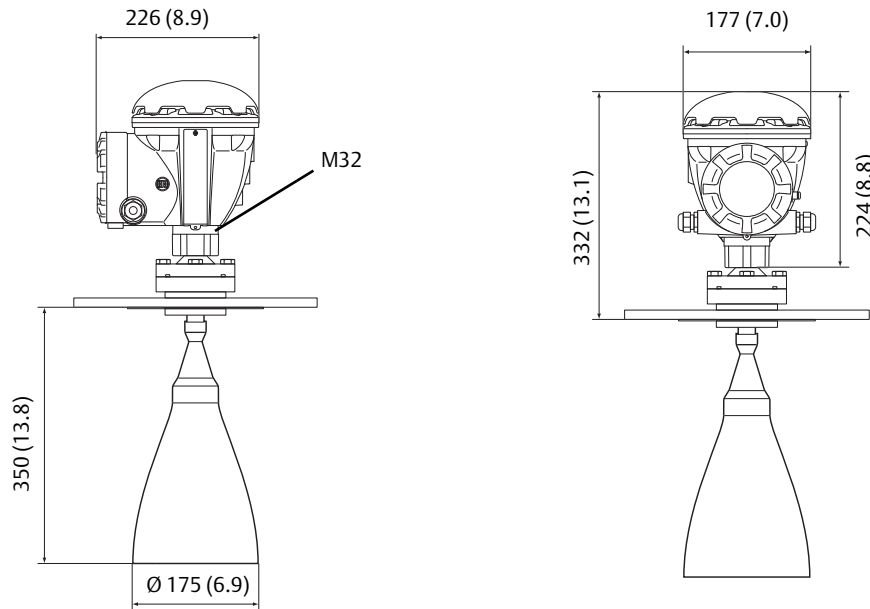

Flange	Minimum Nozzle Diameter	Maximum Nozzle Height
Horizontal flange	180 mm (7.1 in.)	330 mm (13.0 in.)
4° flange	185 mm (7.3 in.)	330 mm (13.0 in.)

Note

Dimensions are in millimeters (inches).

Figure 3. Rosemount 5900S with still-pipe array antenna dimensions

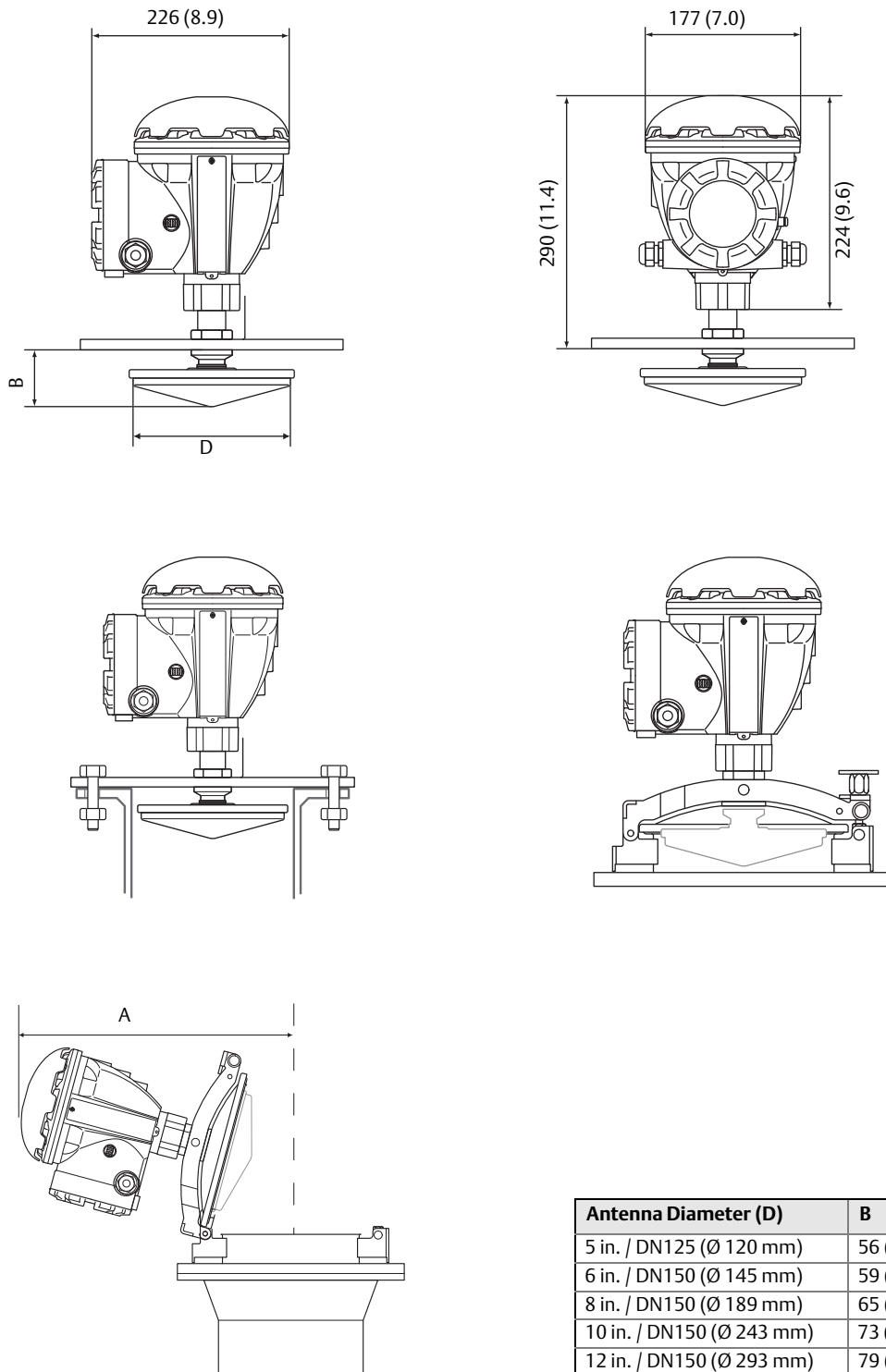

Antenna Diameter (D)	B	A
5 in. / DN125 (Ø 120 mm)	56 (2.2)	470 (18.5)
6 in. / DN150 (Ø 145 mm)	59 (2.3)	470 (18.5)
8 in. / DN150 (Ø 189 mm)	65 (2.6)	480 (18.9)
10 in. / DN150 (Ø 243 mm)	73 (2.9)	490 (19.3)
12 in. / DN150 (Ø 293 mm)	79 (3.1)	490 (19.3)

Note

Dimensions are in millimeters (inches).

Figure 4. Rosemount 5900S with LPG/LNG antenna dimensions

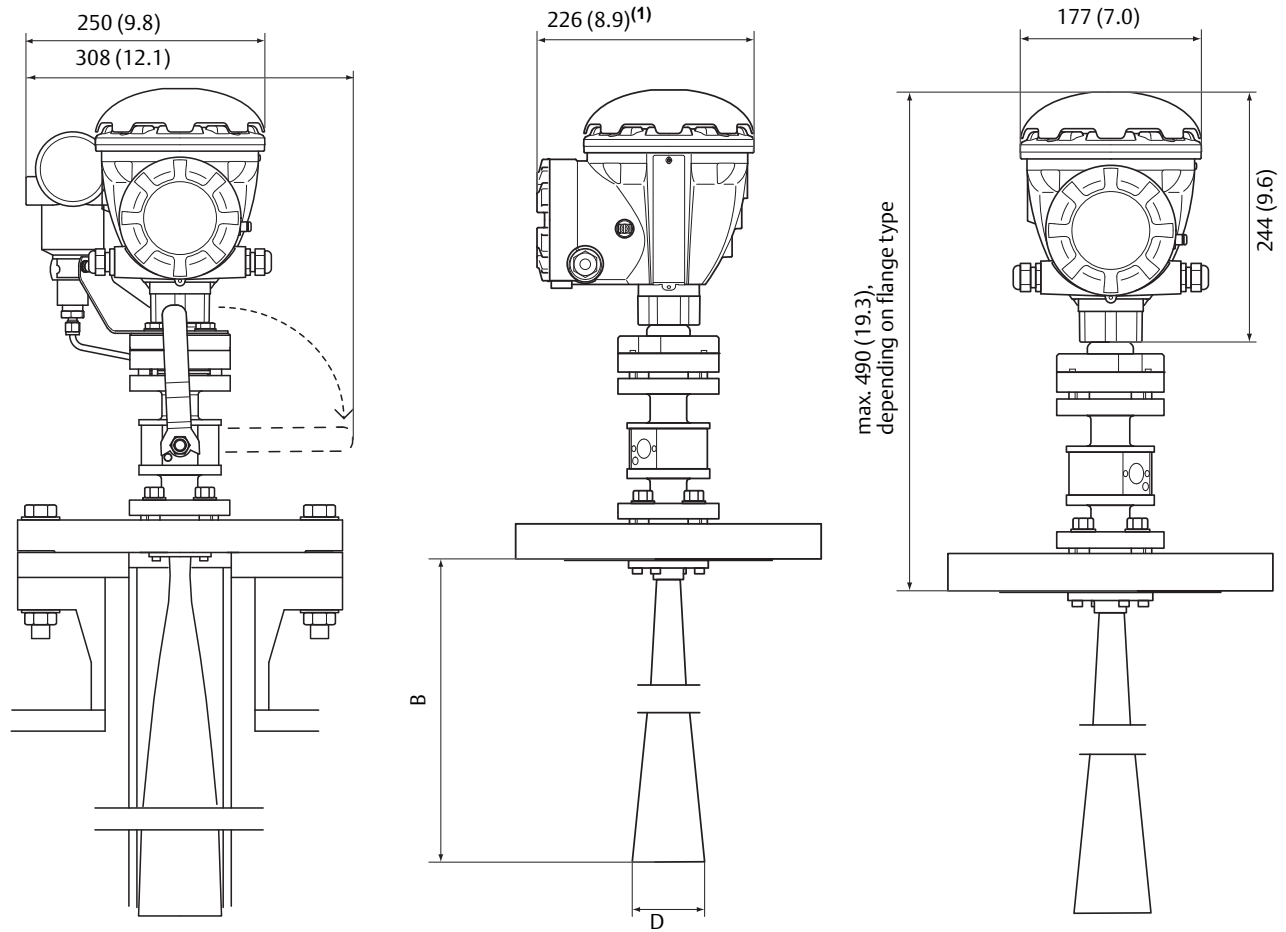

(1) 302 (11.9) with pressure transmitter option

Antenna Diameter (D)	B
4 in. Sch10 (Ø 107 mm)	752 (29.6)
4 in. Sch40 (Ø 101 mm)	534 (21.0)
DN100 (Ø 99 mm)	502 (19.8)

Note

Dimensions are in millimeters (inches).

**Emerson Process Management
Rosemount Tank Gauging**
Box 130 45
SE-402 51 Göteborg
SWEDEN
Tel: +46 31 337 00 00
Fax: +46 31 25 30 22
E-mail: sales.rtg@emerson.com
www.rosemount-tg.com

**Emerson Process Management
Rosemount Tank Gauging North America
Inc.**
6005 Rogerdale Road
Mail Stop NC 136
77072 TX Houston
United States
Primary Phone: +1 281 988 4000
Secondary Phone: +1 800 722 2865
E-mail: sales.rtg.hou@emerson.com

**Emerson Process Management
Latin America**
1300 Concord Terrace, Suite 400
Sunrise Florida 33323
United States
Tel: + 1 954 846 5030

**Emerson Process Management
Rosemount Tank Gauging Middle
East & Africa.**
P. O Box 20048
Manama
Bahrain
Tel: +973 1722 6610
Fax: +973 1722 7771
E-mail: rtgmea.sales@emerson.com

**Emerson Process Management
Asia Pacific Pte Ltd**
1 Pandan Crescent
SINGAPORE 128461
Tel: +65 6777 8211
Fax: +65 6777 0947
E-mail: specialist-itg.rmt-ap@ap.emersonprocess.com

The Emerson logo is a trade mark and service mark of Emerson Electric Co.
Rosemount and the Rosemount logotype are registered trademarks of Rosemount Inc.
PlantWeb is a registered trademark of one of the Emerson Process Management group of companies.
HART and WirelessHART are registered trademarks of the HART Communication Foundation
All other marks are the property of their respective owners.



© 2014 Rosemount Tank Radar AB. All rights reserved.